

The Probe

Solutions for all your vehicle detection scenarios



P5050C Pkg.

The **P5050 Standard** Probe:

- * Non-discriminatory to inbound / outbound traffic
- * Processors used: **111, 212, or 313 (12VDC)**
- * Requires **22/4 shielded direct burial wire w/ Drain**
- * Splice friendly up to 1 mile
- * Commonly used when wire installation and probe installation may not coincide.



P8000C Pkg.

The **P8000 Directional** Probe:

- * Discriminatory to inbound / outbound traffic
- * Processors used: **212 only (12VDC)**
- * Requires **22/4 shielded direct burial wire w/ Drain**
- * Splice friendly up to 1 mile
- * Commonly used when different actions are desired for inbound vs. outbound vehicles **or** when an action is to be taken for vehicle travelling only in a certain direction.



P500B Pkg.

The **P500 Basic** Probe:

- * Non-discriminatory to inbound / outbound traffic
- * Processors used: **P500 only (12VDC)**
- * Requires **any P500 series probe**
- * **Pre-attached 22/2 shielded direct burial wire w/ Drain**
Part # = **P500 - 50 / 125 / 250 / 500 / 1000**
- * Commonly used for gate operation **or** when wire and probe installation coincide.



P5W1 Pkg.

The **P500 Basic** Probe:

- * Non-discriminatory to inbound / outbound traffic
- * Same processor and probes as above
- * White ABS enclosure
- * Purchase with 500 mA or 1.5A power supply
- * Commonly used for driveway annunciation when control box is to be indoors.



WP4C Pkg.

The **WP4 Low Power** Probe System:

- * Non-discriminatory to inbound / outbound traffic
- * Processors used: **WP4 only (9VDC)**
- * Requires **any P500 series Basic Probe**
- * **WP4B - Pkg. w/ no wireless : WP4C - Pkg. (2000 ft.) : WP4CLR - Pkg. (4000 ft.)**
WP4CDE - Pkg. Dual Entrance (2000 ft.) : WP4CDELRL - Pkg. Dual Entrance (4000 ft.)
- * Commonly used when trenching wire is impractical or undesirable.

*Package systems include all components needed except wire. Probes are purchased separately for Basic probe systems.

*All probes are designed for direct burial beside a 14 foot wide driveway.

*All components of package systems may be purchased individually.

All Sure Action probes are devices that monitor the earth's magnetic field within an adjacent 3-dimensional space. A moving vehicle causes a disturbance in this field which induces a small voltage signal. A processor filters this signal and provides a relay output which can be used to drive a chime or other device.

All probes are completely passive devices and emit no energy. All probe systems are momentary devices. They will stabilize around any non-moving ferrous metal within the detection range which means they can not be used as safety devices. **Probe systems will not latch in the presence of metal.** They will only respond to ferrous metal that is in motion.

Best Location
(For Standard & Basic Probes)

Place the probe in the center of the driveway. This allows for the lowest possible sensitivity setting and also for vehicle detection on a driveway up to 28 feet wide.

If the driveway is not yet paved, the Probe should be placed in 2-3" PVC pipe. This allows for access to the Probe after the driveway is paved. The pipe should have a slight pitch for water drainage.

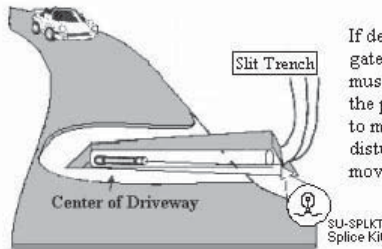

If dealing with ferrous metal gates, several surface tests must be performed before the probe is buried. This is to make sure that there is no disturbance by gate movement.

SECOND BEST LOCATION
(For Standard & Basic Probes)

Bury the probe at the edge of the driveway deep enough to cover it and keep it stationary (usually 6-8"). If the Probe is buried in the ground, place it parallel to the driveway. This will give you the widest window of capture.

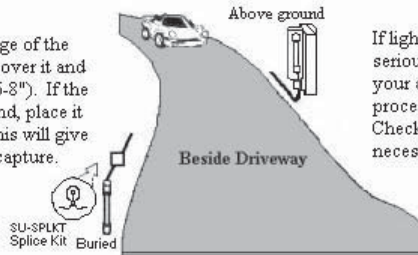

If lightning is a serious problem in your area an SU-212 processor with Check Probe may be necessary.

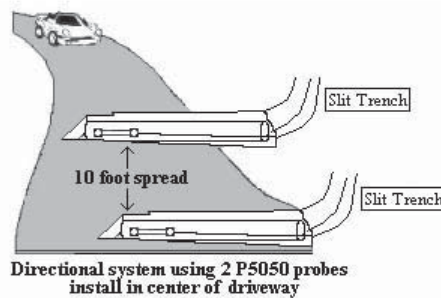
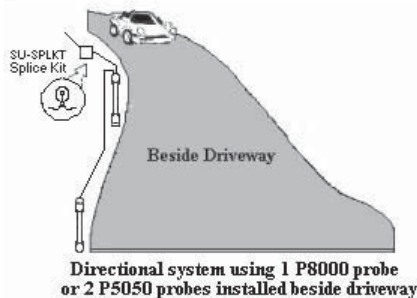

Splice kits are required (supplied) with Standard and Directional Probes only. Basic Probes are supplied with 50, 125, 250, 500, or 1000 foot wire lengths.

Possible ways to bury the Probe

- 1). Center of driveway
 - a). Can cover a driveway up to 28 feet wide.
 - b). Uses the lowest possible sensitivity setting.
 - c). Place Probe in 2" or 3" PVC pipe that is sealed at one end.
 - i). Pipe should be pitched for drainage.
 - ii). Allows for retrieval of Probe
- 2). Along side of driveway
 - a). Bury Probe 6"-8" deep at edge of driveway
 - b). Place Probe parallel to flow of traffic

Do not bury Probe within:

- * 5 ft. of high power cables or transformers
- * 10 ft. of high-power radio transmitter towers
- * 24 ft. of residential traffic
- * 36 ft. of highway traffic
- * 100 ft. of moving trains

Installation:

Step 1: Place Probe at the burial location and connect wire. Do not permanently splice connections yet.

Step 2: Mount processor, connect Probe and power system. Wait (30-40 sec.) for system stabilization (Green L.E.D. On).

Step 3: Test the system. If everything is working correctly bury the Probe and make all connections permanent.

313 Processor

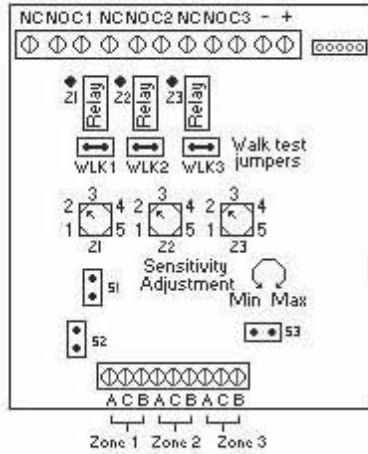

Power Requirement: 12 VDC
Current Consumption: 16 mA per zone (Stable)
 4 mA per zone (Alarm)

Output: Form "C" relay
 Rated (24 VAC, 1 A)
 Approx: 4 Second momentary

Green L.E.D: On = Stable
 Off = Alarm
 * The Green L.E.D will remain on as long as the processor is stable.

Physical Dimensions:
 3.25" W x 4.0" L x 1.0" H
 2.0" W x 2.25" L x 1.0" H

Sensitivity Adjustment(s): 1 = Minimum
 White Wheel(s) 5 = Maximum
The sensitivity setting will not effect the L.E.D.

Black Jumper(s): **Default**
 (Shorted) = Normal (Open) = Walk test mode
 (Open) = Normal Range (Shorted) = High Range

111 Processor

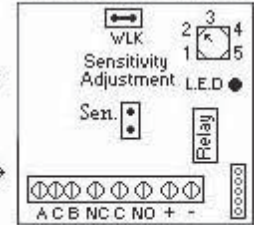

313 (3 zone processor)

- * Operates Pulsors and Probes
- * Maximum of 12 Pulsors (4 per zone)
- * Maximum of 3 Probes (1 per zone) (P5050 Standard Probes only)

111 (1 zone processor)

- * Operates Pulsors and Probes
- * Maximum of 4 Pulsors
- * Maximum of 1 Probe (P5050 Standard Probes only)

Walk test mode is used with Pulsors only
 The Green L.E.D will remain on as long as the processor is stable.

P500 Processor

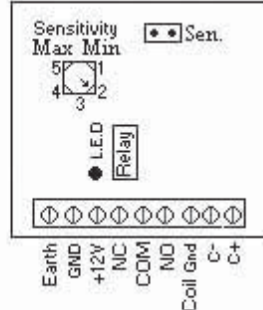

Power Requirement: 12 VDC
Current Consumption: 16 mA (Stable)
 4 mA (Alarm)

Output: Form "C" relay
 Rated (24 VAC, 1 A)
 Approx: 4 Second momentary

Green L.E.D: On = Stable
 Off = Alarm
 * The Green L.E.D will remain on as long as the processor is stable.

Physical Dimensions: 3.0" W x 2.0" L x 9/16" H

Sensitivity Adjustment(s): 1 = Minimum
 White Wheel(s) 5 = Maximum
The sensitivity setting will not effect the L.E.D.

Black Jumper: **Default**
 (Open) = Normal Range (Shorted) = High Range

Contact Sure Action technical support before operating processor in high range.

P500 (Basic Probe Processor)

- * Operates Probes Only
- * Maximum of 2 Probes (P500 Series Probes Only)

212 Processor

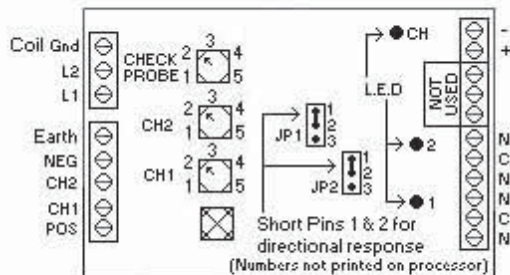

Power Requirement: 12 VDC
Current Consumption: 55 mA

Output: Form "C" relay
 Rated (24 VAC, 1 A)
 Approx: 5 Second momentary

Green L.E.D: On = Stable
 Off = Alarm
 * The Green L.E.D will remain on as long as the processor is stable.

Physical Dimensions: 5.5" L x 3.0" W x 1.0" H

Sensitivity Adjustment(s): 1 = Minimum
 White Wheel(s) 5 = Maximum
The sensitivity setting will not effect the L.E.D.

Directional applications

C2 output activated for inbound vehicles
 C1 output activated for outbound vehicles

Normal applications (Each P5050 Probe acts independently)

CH2 activates C2 output
 CH1 activates C1 output

212 (Directional Probe Processor)

- * Operates Probes only
- * Maximum of 1 P8000 Directional Probe
- * Maximum of 2 P5050 Standard Probes (Directional or Non-directional system)

Directional Mode

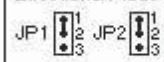

Independent Mode



* If you are not using a Check Probe you must stabilize the Check zone by placing a 1K Ohm resistor between terminals L1 & L2.

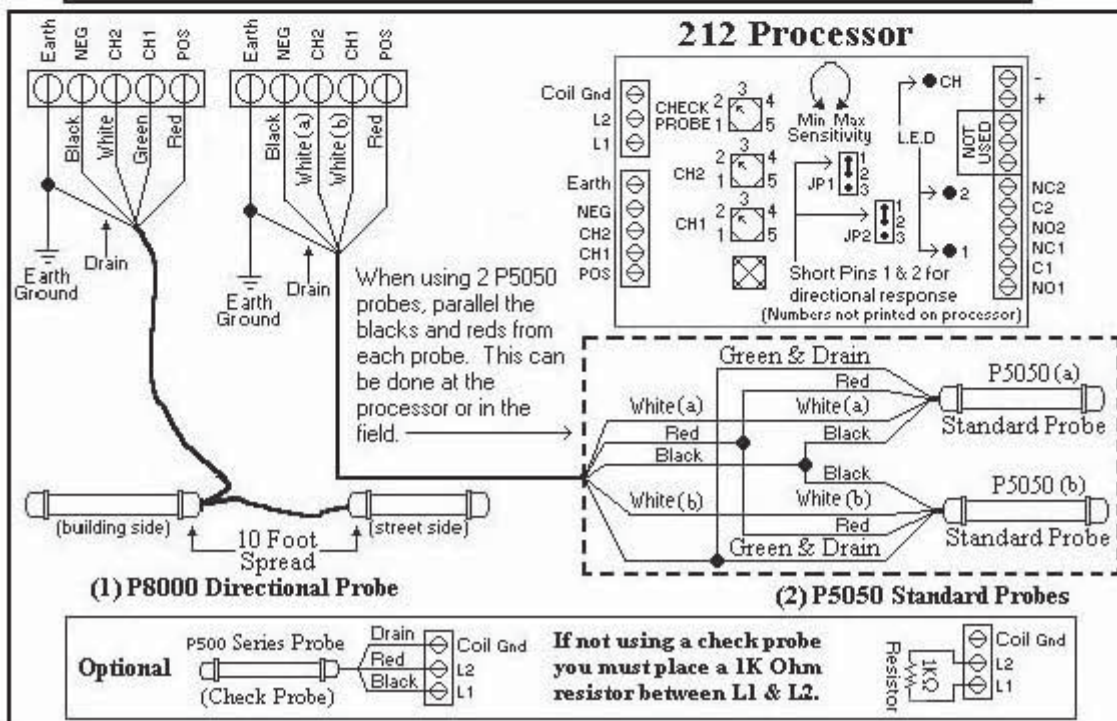
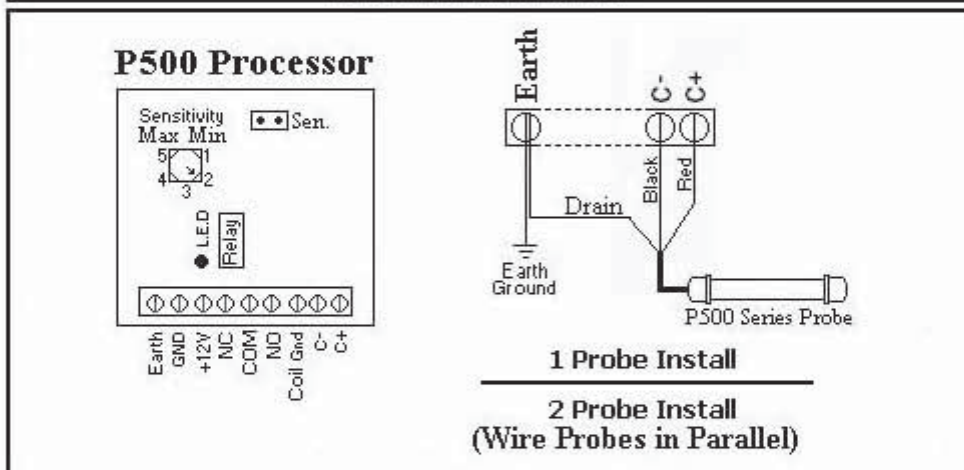
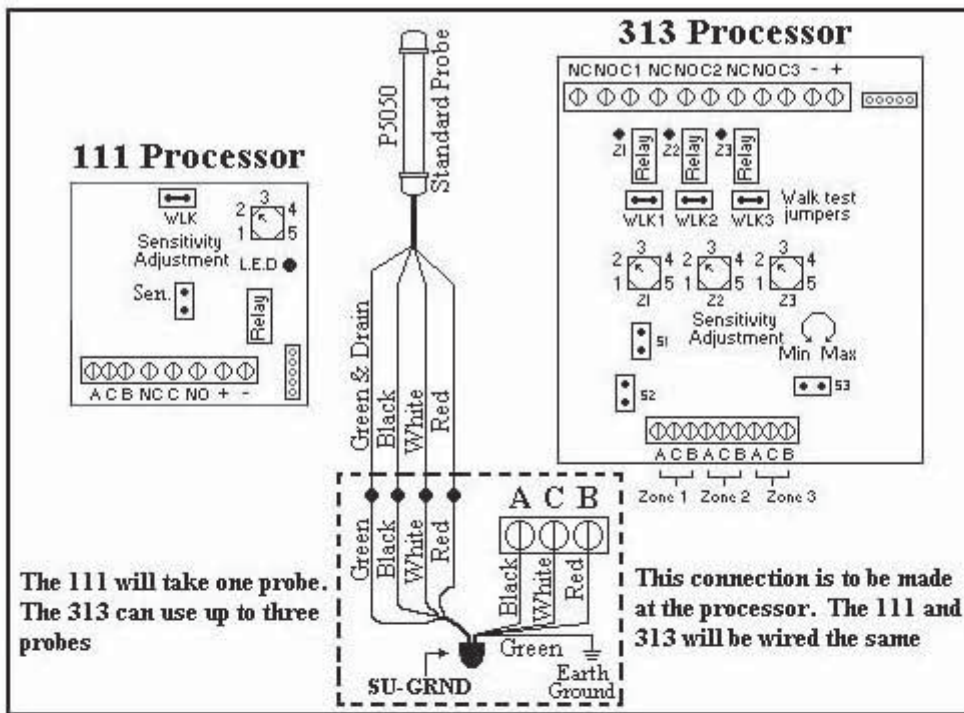

System Troubleshooting

* Probe Field Test - P5050 Standard Probe & P8000 Directional Probe

1. Connect Probe to 12VDC power supply as shown. Red to positive (+) and Black to negative (-).
2. Check the White lead for steady 5.0 - 6.5VDC in relation to (-) of power supply.
3. Move magnet directly over Probe and observe a meter variation of .02 VDC to .10 VDC.
4. *If testing a P8000 Directional Probe, check both the White and Green leads each for a steady 5.0 - 6.5 VDC in relation to (-) of power supply.*

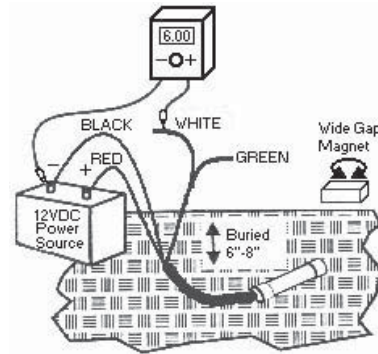

* Probe Field Test - P500 Series Probe

1. Check resistance reading between the Red and Black wires. The resistance reading should be close to the reference number written in Red on the body of the Probe.
2. Move magnet directly over Probe and observe a meter variation of 2 - 10 Ohms.

* Processors - 111 (One Zone) and 313 (Three Zone)

1. Remove Probe from processor and place a 1K Ohm resistor between A & C. Place another 1K Ohm resistor between C & B. Within 30 seconds the processor should stabilize (Green L.E.D on steady).
2. Wet your finger and rub it across the resistors. The L.E.D should momentarily extinguish.
3. Check voltage readings at A, C, & B terminals each in relation to (-) of power. **A = .16 / C = 1.75 / B = 3.35.**

* For 313 processor each zone will be tested individually.

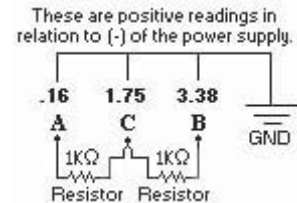

* Processors - (P500 Basic Probe processor)

1. Remove Probe from processor and place a 1K Ohm resistor between C+ and C-. Within 30 seconds the processor should stabilize (Green L.E.D on steady).
2. Wet your finger and rub it across the resistors. The L.E.D should momentarily extinguish.
3. Check voltage readings at C+ and C- each in relation to (-) of power. Both readings should be the same and close to 2.10 VDC.

* Processors - (212 Directional Probe processor)

1. Make sure there is a 1K Ohm resistor between terminals L1 and L2. Voltage reading at L1 or L2 in relation to (-) of power should be close to 2.10 VDC and CH L.E.D should be on.
2. Move JP1 and JP2 so pins 2 & 3 are shorted. This puts the processor into individual mode and allows for the testing of each channel independently.
3. Place 2K Ohms between Neg and CH2 and 3K Ohms between CH2 and Pos. Within 30 seconds channel 2 should stabilize (Green L.E.D on steady). CH2 to (-) of power should be 2 VDC.
4. Wet your finger and rub it across the resistors. L.E.D 2 should momentarily extinguish.
5. Place 2K Ohms between Neg and CH1 and 3K Ohms between CH1 and Pos. Within 30 seconds channel 1 should stabilize (Green L.E.D on steady).
6. Wet your finger and rub it across the resistors. L.E.D 1 should momentarily extinguish. CH2